

CBSE PM/PD 2010

CHEMISTRY

1. For the reaction $\text{N}_2\text{O}_5 (\text{g}) \longrightarrow 2\text{NO}_2 (\text{g}) + 1/2 \text{O}_2 (\text{g})$ the value of rate of disappearance of N_2O_5 is given as $6.25 \times 10^{-3} \text{ mol L}^{-1} \text{ s}^{-1}$. The rate of formation of NO_2 and O_2 is given respectively as:

(1) $6.25 \times 10^{-3} \text{ mol L}^{-1} \text{ s}^{-1}$ and

$6.25 \times 10^{-3} \text{ mol L}^{-1} \text{ s}^{-1}$

(2) $1.25 \times 10^{-2} \text{ mol L}^{-1} \text{ s}^{-1}$ and

$3.125 \times 10^{-3} \text{ mol L}^{-1} \text{ s}^{-1}$

(3) $6.25 \times 10^{-3} \text{ mol L}^{-1} \text{ s}^{-1}$ and

$3.125 \times 10^{-3} \text{ mol L}^{-1} \text{ s}^{-1}$

(4) $1.25 \times 10^{-2} \text{ mol L}^{-1} \text{ s}^{-1}$ and

$6.25 \times 10^{-3} \text{ mol L}^{-1} \text{ s}^{-1}$

Sol: $\text{N}_2\text{O}_5 (\text{g}) \longrightarrow 2 \text{NO}_2 (\text{g}) + 1/2 \text{O}_2 (\text{g})$

$$-\frac{d}{dt} [\text{N}_2\text{O}_5] = + \frac{1}{2} \frac{d}{dt} [\text{NO}_2] = 2 \frac{d}{dt} [\text{O}_2]$$

$$\frac{d}{dt} [\text{NO}_2] = 1.25 \times 10^{-2} \text{ mol L}^{-1} \text{ s}^{-1} \text{ and}$$

$$\frac{d}{dt} [\text{O}_2] = 3.125 \times 10^{-3} \text{ mol L}^{-1} \text{ s}^{-1}$$

∴ Correct choice : (2)

2. Liquid hydrocarbons can be converted to a mixture of gaseous hydrocarbons by:

(1) Oxidation

(2) Cracking

(3) Distillation under reduced pressure

(4) Hydrolysis

Sol: During cracking, lower gaseous hydrocarbons are formed.

∴ Correct choice : (2)

3. In which of the following pairs of molecules/ions, the central atoms have sp^2 hybridization?

(1) NO_2^- and NH_3

(2) BF_3 and NO_2^-

(3) NH_2^- and H_2O

(4) BF_3 and NH_2^-

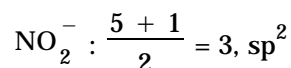
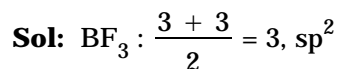

∴ **Correct choice : (2)**

4. Which one of the following does **not** exhibit the phenomenon of mutarotation?

(1) (+) Sucrose

(2) (+) Lactose

(3) (+) Maltose

(4) (–) Fructose

Sol: Sucrose does not have free – CHO and CO groups

∴ **Correct choice : (1)**

5. Which one of the following species does not exist under normal conditions?

(1) Be_2^+

(2) Be_2

(3) B_2

(4) Li_2

Sol: Bond order of $\text{Be}_2 = 0$, cannot exist

∴ **Correct choice : (2)**

6. Which of the following complex ion is not expected to absorb visible light?

(1) $[\text{Ni}(\text{CN})_4]^{2-}$

(2) $[\text{Cr}(\text{NH}_3)_6]^{3+}$

(3) $[\text{Fe}(\text{H}_2\text{O})_6]^{2+}$

(4) $[\text{Ni}(\text{H}_2\text{O})_6]^{2+}$

Sol: $[\text{Ni}(\text{CN})_4]^{2-}$: Number of unpaired electrons – 0

$[\text{Cr}(\text{NH}_3)_6]^{3+}$: Number of unpaired electrons – 3

$[\text{Fe}(\text{H}_2\text{O})_6]^{2+}$: Number of unpaired electrons – 4

$[\text{Ni}(\text{H}_2\text{O})_6]^{2+}$: Number of unpaired electrons – 2

∴ **Correct choice : (1)**

7. Given are cyclohexanol (I), acetic acid (II), 2, 4, 6-trinitrophenol (III) and phenol (IV). In these the order of decreasing acidic character will be:

(1) III > II > IV > I (2) II > III > I > IV (3) II > III > IV > I (4) III > IV > II > I

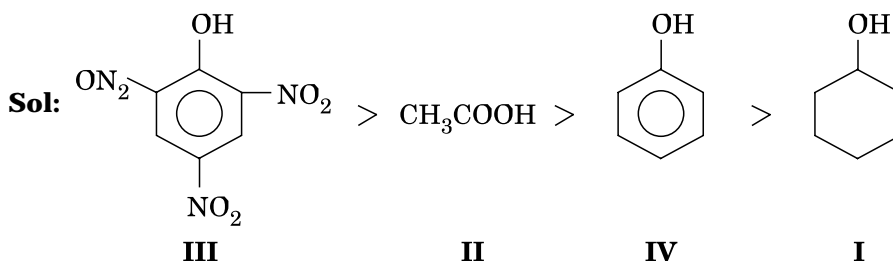

∴ **Correct choice : (1)**

8. If pH of a saturated solution of Ba(OH)_2 is 12, the value of its K_{SP} is:

- (1) $4.00 \times 10^{-6} \text{ M}^3$ (2) $4.00 \times 10^{-7} \text{ M}^3$ (3) $5.00 \times 10^{-6} \text{ M}^3$ (4) $5.00 \times 10^{-7} \text{ M}^3$

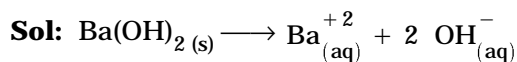

$$\text{pH} = 12 \text{ or } \text{pOH} = 2$$

$$[\text{OH}^-] = 10^{-2} \text{ M}$$

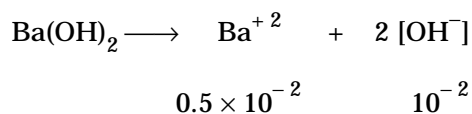

$$\begin{aligned} K_{\text{sp}} &= [\text{Ba}^{+2}] [\text{OH}^-]^2 \\ &= [0.5 \times 10^{-2}] [1 \times 10^{-2}]^2 \\ &= 0.5 \times 10^{-6} = 5 \times 10^{-7} \text{ M}^3 \end{aligned}$$

∴ Correct choice : (4)

9. The reaction of toluene with Cl_2 in presence of FeCl_3 gives 'X' and reaction in presence of light gives 'Y'. Thus, 'X' and 'Y' are:

- (1) X = Benzal chloride, Y = o-chlorotoluene
 (2) X = m-chlorotoluene, Y = p-chlorotoluene
 (3) X = o-and p-chlorotoluene,
 Y = Trichloromethyl benzene
 (4) X = Benzyl chloride, Y = m-chlorotoluene

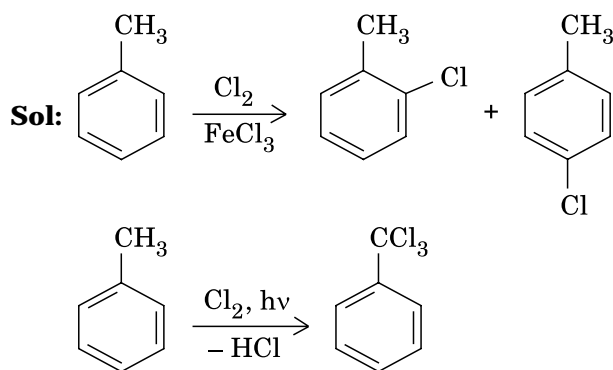

∴ Correct choice : (3)

10. Which one of the following compounds has the most acidic nature?

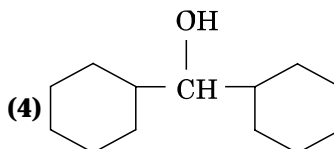
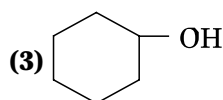
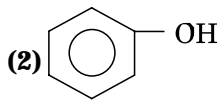
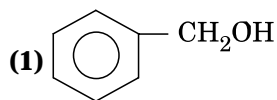

Sol: Phenol is most acidic, the other compounds are alcohols

∴ **Correct choice : (2)**

11. In a set of reactions, ethyl benzene yielded a product D.

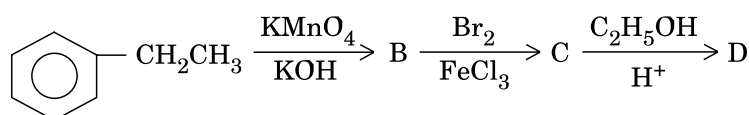

'D' would be:

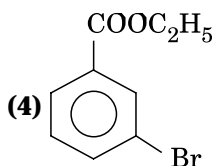
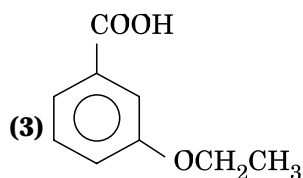
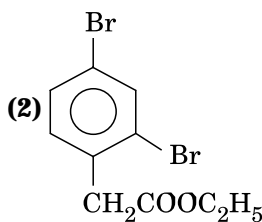
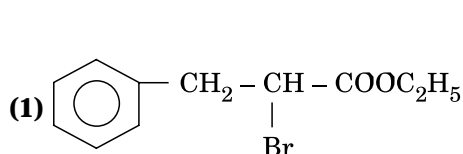

Sol:

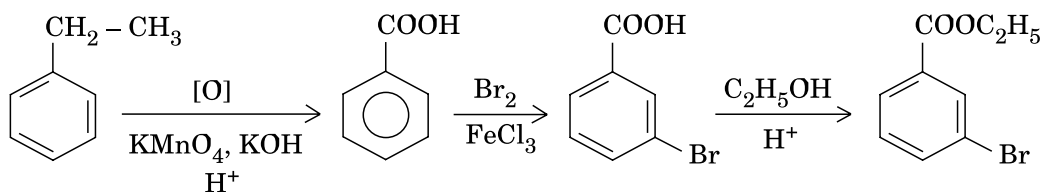

∴ **Correct choice : (4)**

12. What is $[\text{H}^+]$ in mol/L of a solution that is 0.20 M in CH_3COONa and 0.10 M in CH_3COOH ? K_a for $\text{CH}_3\text{COOH} = 1.8 \times 10^{-5}$.

(1) 3.5×10^{-4}

(2) 1.1×10^{-5}

(3) 1.8×10^{-5}

(4) 9.0×10^{-6}

Sol: Tertiary alkyl halide has the highest rate in nucleophilic substitution. Aryl halide has the least rate due to partial double character.

Presence of $-\text{NO}_2$ groups in ortho and para positions will increase the reactivity

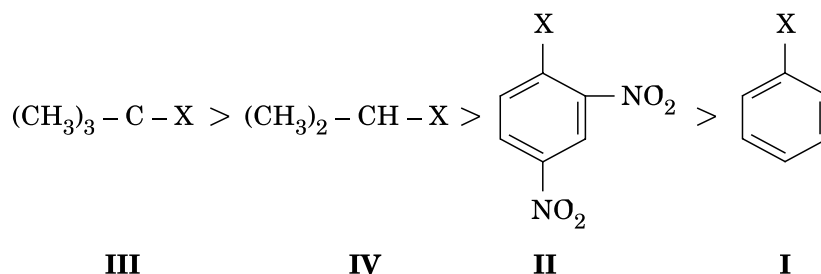

or $\text{I} < \text{II} < \text{IV} < \text{III}$

\therefore **Correct choice : (1)**

15. For the reduction of silver ions with copper metal, the standard cell potential was found to be $+0.46\text{ V}$ at 25°C . The value of standard Gibbs energy, ΔG^0 will be ($F = 96500\text{ C mol}^{-1}$)

- (1) -89.0 kJ (2) -89.0 J (3) -44.5 kJ (4) -98.0 kJ

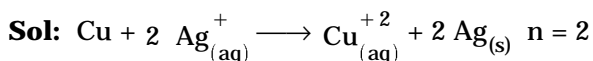

$$E_{\text{cell}}^0 = +0.46\text{ V}$$

$$\Delta G^0 = -nE^0 F$$

$$= \frac{-2 \times 0.46 \times 96500}{1000}\text{ kJ}$$

$$\simeq -89\text{ kJ}$$

\therefore **Correct choice : (1)**

16. In which of the following equilibrium K_c and K_p are not equal?

- (1) $2\text{NO}_{(\text{g})} \rightleftharpoons \text{N}_{2(\text{g})} + \text{O}_{2(\text{g})}$
 (2) $\text{SO}_{2(\text{g})} + \text{NO}_{2(\text{g})} \rightleftharpoons \text{SO}_{3(\text{g})} + \text{NO}_{(\text{g})}$
 (3) $\text{H}_{2(\text{g})} + \text{I}_{2(\text{g})} \rightleftharpoons 2\text{HI}_{(\text{g})}$
 (4) $2\text{C}_{(\text{s})} + \text{O}_{2(\text{g})} \rightleftharpoons 2\text{CO}_{2(\text{g})}$

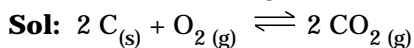

$$\Delta n = 2 - 1 = +1$$

$\therefore K_c$ and K_p are not equal

\therefore **Correct choice : (4)**

17. Which of the following ions will exhibit colour in aqueous solutions?

- (1) La^{3+} (Z = 57) (2) Ti^{3+} (Z = 22) (3) Lu^{3+} (Z = 71) (4) Sc^{3+} (Z = 21)

Sol: La^{3+} : $54 e^- = [\text{Xe}]$

Ti^{3+} : $19 e^- = [\text{Ar}] 3d^1$ (colour)

Lu^{3+} : $68 e^- = [\text{Xe}] 4f^{14}$

Sc^{3+} : $18 e^- = [\text{Ar}]$

∴ **Correct choice : (2)**

18. Aniline in a set of the following reactions yielded a coloured product 'Y'.

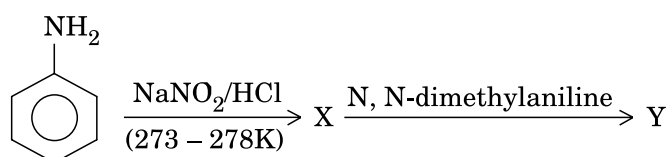

The structure of 'Y' would be:

- (1)
- (2)
- (3)
- (4)

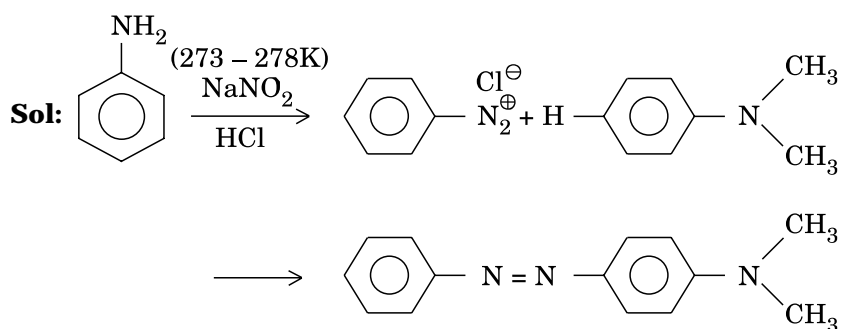

∴ **Correct choice : (1)**

19. Acetamide is treated with the following reagents separately. Which one of these would yield methylamine?

- (1) NaOH – Br₂ (2) Sodalime (3) Hot conc. H₂SO₄ (4) PCl₅

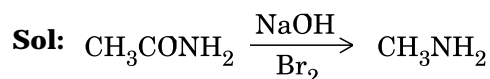

∴ **Correct choice : (1)**

20. An aqueous solution is 1.00 molal in KI. Which change will cause the vapour pressure of the solution to increase?

- (1) Addition of NaCl (2) Addition of Na₂SO₄
(3) Addition of 1.00 molal KI (4) Addition of water

Sol: When the aqueous solution of one molal KI is diluted with water, concentration decreases, therefore the vapour pressure of the resulting solution increases.

∴ **Correct choice : (4)**

21. A solution of sucrose (molar mass = 342 g mol⁻¹) has been prepared by dissolving 68.5 g of sucrose in 1000 g of water. The freezing point of the solution obtained will be: (K_f for water = 1.86 K kg mol⁻¹)

- (1) – 0.372°C (2) – 0.520°C (3) + 0.372°C (4) – 0.570°C

Sol: $\Delta T_f = K_f \frac{1000 W_2}{M_2 W_1} = \frac{1.86 \times 1000 \times 68.5}{342 \times 1000} = 0.372$

$T_f = -0.372^\circ\text{C}$

∴ **Correct choice : (1)**

22. Which of the following alkaline earth metal sulphates has hydration enthalpy higher than the lattice enthalpy?

- (1) CaSO₄ (2) BeSO₄ (3) BaSO₄ (4) SrSO₄

Sol: Be⁺² is very small, hence its hydration enthalpy is greater than its lattice enthalpy

∴ **Correct choice : (2)**

23. Which one of the following ions has electronic configuration [Ar] 3d⁶?

- (1) Ni³⁺
(2) Mn³⁺
(3) Fe³⁺
(4) Co³⁺

(At. Nos. Mn = 25, Fe = 26, Co = 27, Ni = 28)

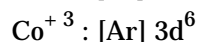
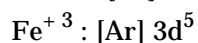
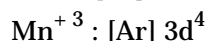
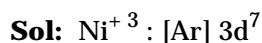

∴ **Correct choice : (4)**

24. An increase in equivalent conductance of a strong electrolyte with dilution is mainly due to:

- (1) increase in ionic mobility of ions
- (2) 100% ionisation of electrolyte at normal dilution
- (3) increase in both i.e. number of ions and ionic mobility of ions
- (4) increase in number of ions

∴ **Correct choice : (1)**

25. Crystal field stabilization energy for high spin d^4 octahedral complex is:

- (1) $-1.8 \Delta_0$
- (2) $-1.6 \Delta_0 + P$
- (3) $-1.2 \Delta_0$
- (4) $-0.6 \Delta_0$

Sol: d^4 in high spin octahedral complex

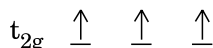

$$\text{CFSE} = [0.6 \times 1] + [-0.4 \times 3] = -0.6 \Delta_0$$

∴ **Correct choice : (4)**

26. Oxidation states of P in $\text{H}_4\text{P}_2\text{O}_5$, $\text{H}_4\text{P}_2\text{O}_6$, $\text{H}_4\text{P}_2\text{O}_7$ are respectively:

- (1) +3, +5, +4
- (2) +5, +3, +4
- (3) +5, +4, +3
- (4) +3, +4, +5

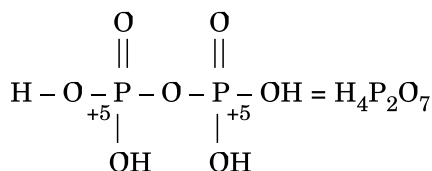
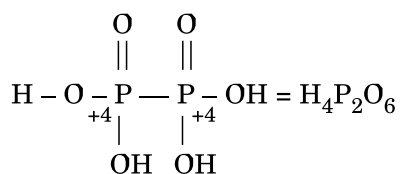
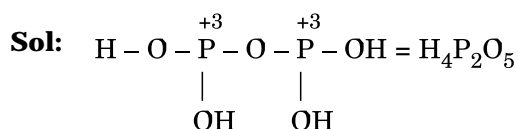

∴ **Correct choice : (4)**

27. Which of the following statements about primary amines is 'False'?

- (1) Alkyl amines are stronger bases than aryl amines
- (2) Alkyl amines react with nitrous acid to produce alcohols
- (3) Aryl amines react with nitrous acid to produce phenols
- (4) Alkyl amines are stronger bases than ammonia

Sol: Aryl amines will not produce phenol on Treatment with nitrous acid.

∴ **Correct choice : (3)**

28. The correct order of increasing bond angles in the following species are:

- (1) $\text{Cl}_2\text{O} < \text{ClO}_2 < \text{ClO}_2^-$
- (2) $\text{ClO}_2 < \text{Cl}_2\text{O} < \text{ClO}_2^-$
- (3) $\text{Cl}_2\text{O} < \text{ClO}_2^- < \text{ClO}_2$
- (4) $\text{ClO}_2^- < \text{Cl}_2\text{O} < \text{ClO}_2$

Sol: The correct order of increasing bond angle is $\text{Cl}_2\text{O} < \text{ClO}_2^- < \text{ClO}_2$

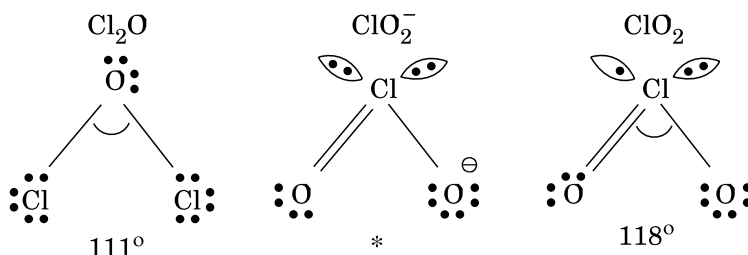

* In ClO_2^- there are 2 lone pairs of electrons present on the central chlorine atom.

Therefore the bond angle in ClO_2^- is less than 118° which is the bond angle in ClO_2 which has less number of electrons on chlorine.

∴ **Correct choice : (3)**

29. Among the given compounds, the most susceptible to nucleophilic attack at the carbonyl group is:

- (1) $\text{CH}_3\text{COOCH}_3$
- (2) CH_3CONH_2
- (3) $\text{CH}_3\text{COOCOCH}_3$
- (4) CH_3COCl

Sol: Cl^- is the weakest base and hence better leaving group

∴ **Correct choice : (4)**

30. 25.3 g of sodium carbonate, Na_2CO_3 is dissolved in enough water to make 250 mL of solution. If sodium carbonate dissociates completely, molar concentration of sodium ion, Na^+ and carbonate ions, CO_3^{2-} are respectively (Molar mass of $\text{Na}_2\text{CO}_3 = 106 \text{ g mol}^{-1}$)

- (1) 0.955 M and 1.910 M
- (2) 1.910 M and 0.955 M
- (3) 1.90 M and 1.910 M
- (4) 0.477 M and 0.477 M

Sol: Concentration of $\text{Na}_2\text{CO}_3 = \frac{25.3}{106} \times \frac{1000}{250} = 0.955 \text{ M}$

$$[\text{Na}^+] = 2 \times 0.955 = 1.91 \text{ M}$$

$$\left[\text{CO}_3^{-2} \right] = 0.955 \text{ M}$$

∴ **Correct choice : (2)**

31. In a buffer solution containing equal concentration of B^- and HB , the K_b for B^- is 10^{-10} . The pH of buffer solution is:

- (1) 10 (2) 7 (3) 6 (4) 4

Sol: $K_b = 10^{-10}$; $K_a = 10^{-4}$ or $\text{p}K_a = 4$

For the buffer solution containing equal concentration of B^- and HB

$$\text{pH} = \text{p}K_a + \log 1$$

$$\text{pH} = \text{p}K_a = 4$$

∴ **Correct choice : (4)**

32. The existence of two different coloured complexes with the composition of $[\text{Co}(\text{NH}_3)_4\text{Cl}_2]^+$ is due to:

- (1) linkage isomerism (2) geometrical isomerism
(3) coordination isomerism (4) ionization isomerism

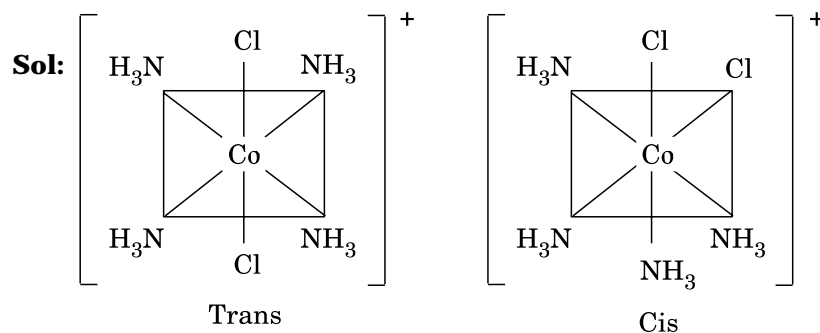

∴ **Correct choice : (2)**

33. Property of the alkaline earth metals that increases with their atomic number:

- (1) Solubility of their hydroxides in water
(2) Solubility of their sulphates in water
(3) Ionization energy
(4) Electronegativity

Sol: Lattice energy decreases more rapidly than hydration energy for alkaline earth metal hydroxides

∴ **Correct choice : (1)**

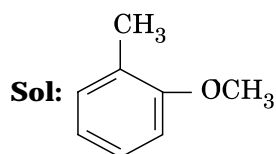

Methoxy group has the highest + M effect.

∴ **Correct choice : (4)**

42. Which one of the following is employed as a Tranquilizer drug?

- (1) Promethazine (2) Valium (3) Naproxen (4) Mifepristone

∴ **Correct choice : (2)**

43. In the following the most stable conformation of n-butane is:

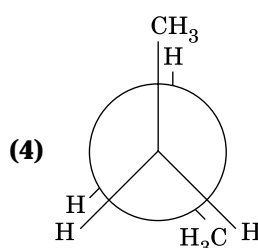
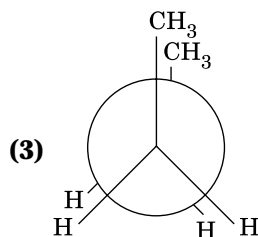
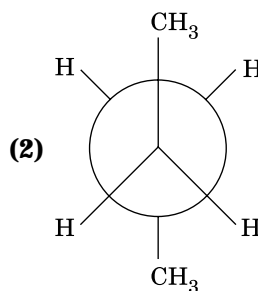
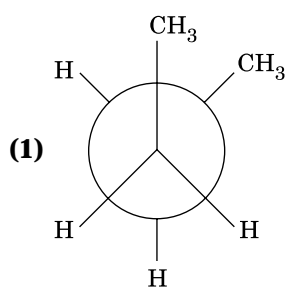

∴ **Correct choice : (2)**

44. Which of the following reactions will **not** result in the formation of carbon-carbon bonds?

- (1) Reimer-Tieman reaction (2) Cannizaro reaction
(3) Wurtz reaction (4) Friedel-Crafts acylation

∴ **Correct choice : (2)**

45. Which of the following structures represents Neoprene polymer?

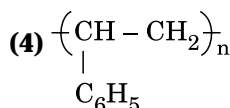
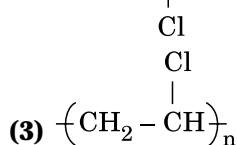
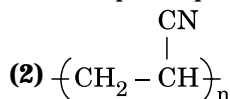
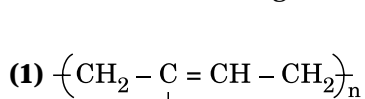

∴ **Correct choice : (1)**

46. Which one is most reactive towards S_N1 reaction?

- (1) $C_6H_5CH(C_6H_5)Br$ (2) $C_6H_5CH(CH_3)Br$
 (3) $C_6H_5C(CH_3)(C_6H_5)Br$ (4) $C_6H_5CH_2Br$

Sol: Tertiary carbonium ion formed is stabilized by two phenyl groups and one methyl group.

∴ **Correct choice : (3)**

47. AB crystallizes in a body centred cubic lattice with edge length 'a' equal to 387 pm. The distance between two oppositely charged ions in the lattice is:

- (1) 335 pm (2) 250 pm (3) 200 pm (4) 300 pm

Sol: For BCC lattice body diagonal is equal to $a\sqrt{3}$

The distance between the two oppositely charged ions = $\frac{a}{2}\sqrt{3}$

$$= \frac{387 \times 1.732}{2} = 335 \text{ pm}$$

∴ **Correct choice : (1)**

48. The number of atoms in 0.1 mol of a triatomic gas is: ($N_A = 6.02 \times 10^{23} \text{ mol}^{-1}$)

- (1) 6.026×10^{22} (2) 1.806×10^{23} (3) 3.600×10^{23} (4) 1.800×10^{22}

Sol: The number of atoms in 0.1 mole of a triatomic gas = $0.1 \times 3 \times 6.023 \times 10^{23}$

$$= 1.806 \times 10^{23}$$

∴ **Correct choice : (2)**

49. Which one of the following molecular hydrides acts as a Lewis acid ?

- (1) NH_3 (2) H_2O (3) B_2H_6 (4) CH_4

∴ **Correct choice : (3)**

50. The tendency of BF_3 , BCl_3 and BBr_3 to behave as Lewis acid decreases in the sequence:

- (1) $BCl_3 > BF_3 > BBr_3$ (2) $BBr_3 > BCl_3 > BF_3$
 (3) $BBr_3 > BF_3 > BCl_3$ (4) $BF_3 > BCl_3 > BBr_3$

Sol: p-p overlap between B and F is maximum due to identical size and energy of p-orbitals, so electron deficiency in boron of BF_3 is neutralized partially to the maximum extent by back donation.

Hence BF_3 is least acidic

∴ **Correct choice : (2)**

BIOLOGY

51. **In vitro** fertilisation is a technique that involves transfer of which one of the following into the fallopian tube?

- (1) Embryo only, upto 8 cell stage
- (2) Either zygote or early embryo upto 8 cell stage
- (3) Embryo of 32 cell stage
- (4) Zygote only

Sol: (1) is correct choice because the embryo is introduced into fallopian tube.

52. Which one of the following structures between two adjacent cells is an effective transport pathway?

- (1) Plasmodesmata
- (2) Plastoquinones
- (3) Endoplasmic reticulum
- (4) Plasmalemma

∴ **Correct choice : (1)**

53. Single-celled eukaryotes are included in:

- (1) Protista
- (2) Fungi
- (3) Archaea
- (4) Monera

∴ **Correct choice : (1)**

54. The genetically-modified (GM) brinjal in India has been developed for:

- (1) Insect-resistance
- (2) Enhancing shelf life
- (3) Enhancing mineral content
- (4) Drought-resistance

∴ **Correct choice : (1)**

55. In unilocular ovary with a single ovule the placentation is :

- (1) Marginal
- (2) Basal
- (3) Free Central
- (4) Axile

∴ **Correct choice : (2)**

56. An element playing important role in nitrogen fixation is :

- (1) Molybdenum
- (2) Copper
- (3) Manganese
- (4) Zinc

∴ **Correct choice : (1)**

57. Sertoli cells are found in:

- (1) ovaries and secrete progesterone
- (2) adrenal cortex and secrete adrenaline
- (3) seminiferous tubules and provide nutrition to germ cells
- (4) pancreas and secrete cholecystokinin

∴ **Correct choice : (3)**

58. Which one of the following cannot be explained on the basis of Mendel's Law of Dominance?

- (1) The discrete unit controlling a particular character is called a factor
- (2) Out of one pair of factors one is dominant, and the other recessive
- (3) Alleles do not show any blending and both the characters recover as such in F_2 generation.
- (4) Factors occur in pairs

∴ **Correct choice : (3)**

59. Apomictic embryos in **citrus** arise from:

- (1) Synergids
- (2) Maternal sporophytic tissue in ovule
- (3) Antipodal cells
- (4) Diploid egg

∴ **Correct choice : (2)**

60. One example of animals having a single opening to the outside that serves both as mouth as well as anus is:

- (1) **Octopus**
- (2) **Asterias**
- (3) **Ascidia**
- (4) **Fasciola**

∴ **Correct choice : (3)**

61. Select the **correct** statement from the ones given below:

- (1) Barbiturates when given to criminals make them tell the truth
- (2) Morphine is often given to persons who have undergone surgery as a pain killer
- (3) Chewing tobacco lowers blood pressure and heart rate
- (4) Cocaine is given to patients after surgery as it stimulates recovery

∴ **Correct choice : (2)**

62. Listed below are four respiratory capacities (a – d) and four jumbled respiratory volumes of a normal human adult:

Respiratory capacities	Respiratory volumes
(a) Residual volume	2500 mL
(b) Vital capacity	3500 mL
(c) Inspiratory reserve volume	1200 mL
(d) Inspiratory capacity	4500 mL

Which one of the following is the **correct** matching of two capacities and volumes?

- (1) (b) 2500 mL, (c) 4500 mL
- (2) (c) 1200 mL, (d) 2500 mL
- (3) (d) 3500 mL, (a) 1200 mL
- (4) (a) 4500 mL, (b) 3500 mL

∴ **Correct choice : (3)**

63. The chief water conducting elements of xylem in gymnosperms are:
(1) Vessels (2) Fibres
(3) Transfusion tissue (4) Tracheids
∴ **Correct choice : (4)**
64. Ringworm in humans is caused by :
(1) Bacteria (2) Fungi (3) Nematodes (4) Viruses
∴ **Correct choice : (2)**
65. Which one of the following is **not** a micronutrient?
(1) Molybdenum (2) Magnesium (3) Zinc (4) Boron
∴ **Correct choice : (2)**
66. Membrane-bound organelles are **absent** in :
(1) **Saccharomyces** (2) **Streptococcus**
(3) **Chlamydomonas** (4) **Plasmodium**
∴ **Correct choice : (2)**
67. Vasa efferentia are the ductules leading from:
(1) Testicular lobules to rete testis (2) Rete testis to vas deferens
(3) Vas deferens to epididymis (4) Epididymis to urethra
∴ **Correct choice : (2)**
68. Select the **correct** statement from the following:
(1) Biogas is produced by the activity of aerobic bacteria on animal waste
(2) **Methanobacterium** is an aerobic bacterium found in rumen of cattle
(3) Biogas, commonly called gobar gas, is **pure** methane
(4) Activated sludge-sediment in settlement tanks of sewage treatment plant is a rich source of aerobic bacteria
Sol: (4) because small amounts are used as inoculum in secondary treatment or biological treatment stage of sewage treatment.
69. Select the **two correct** statements out of the four (a – d) given below about lac operon.
(a) Glucose or galactose may bind with the repressor and inactivate it
(b) In the absence of lactose the repressor binds with the operator region
(c) The z-gene codes for permease
(d) This was elucidated by Francois Jacob and Jacque Monod
The correct statements are:
(1) (b) and (c) (2) (a) and (c) (3) (b) and (d) (4) (a) and (b)
∴ **Correct choice : (3)**

70. Keel is characteristic of the flowers of :
(1) Gulmohur (2) **Cassia**
(3) **Calotropis** (4) Bean
∴ **Correct choice : (4)**
71. The kind of epithelium which forms the inner walls of blood vessels is :
(1) cuboidal epithelium
(2) columnar epithelium
(3) ciliated columnar epithelium
(4) squamous epithelium
∴ **Correct choice : (4)**
72. Which one of the following has its own DNA?
(1) Mitochondria (2) Dictyosome
(3) Lysosome (4) Peroxisome
∴ **Correct choice : (1)**
73. Transfer of pollen grains from the anther to the stigma of another flower of the same plant is called:
(1) Xenogamy (2) Geitonogamy
(3) Karyogamy (4) Autogamy
∴ **Correct choice : (2)**
74. The genotype of a plant showing the dominant phenotype can be determined by :
(1) Test cross (2) Dihybrid cross
(3) Pedigree analysis (4) Back cross
∴ **Correct choice : (1)**
75. PGA as the first CO₂ fixation product was discovered in photosynthesis of :
(1) Bryophyte (2) Gymnosperm
(3) Angiosperm (4) Alga
∴ **Correct choice : (4)**
76. Study the four statements (a – d) given below and select the two **correct** ones out of them:
(a) A lion eating a deer and a sparrow feeding on grain are ecologically similar in being consumers
(b) Predator star fish **Pisaster** helps in maintaining species diversity of some invertebrates
(c) Predators ultimately lead to the extinction of prey species
(d) Production of chemicals such as nicotine, strychnine by the plants are metabolic disorders
The two correct statements are:
(1) (b) and (c) (2) (c) and (d) (3) (a) and (d) (4) (a) and (b)
∴ **Correct choice : (4)**

77. Seminal plasma in human males is rich in :
(1) fructose and calcium (2) glucose and calcium
(3) DNA and testosterone (4) ribose and potassium
∴ **Correct choice : (1)**
78. ABO blood groups in humans are controlled by the gene I. It has three alleles – I^A , I^B and i. Since there are three different alleles, six different genotypes are possible. How many phenotypes can occur?
(1) Three (2) One (3) Four (4) Two
∴ **Correct choice : (3)**
79. Breeding of crops with high levels of minerals, vitamins and proteins is called :
(1) Somatic hybridisation (2) Biofortification
(3) Biomagnification (4) Micropropagation
∴ **Correct choice : (2)**
80. A common biocontrol agent for the control of plant diseases is :
(1) Baculovirus (2) **Bacillus thuringiensis**
(3) **Glomus** (4) **Trichoderma**
∴ **Correct choice : (4)**
81. Widal test is used for the diagnosis of:
(1) Malaria (2) Pneumonia (3) Tuberculosis (4) Typhoid
∴ **Correct choice : (4)**
82. Injury to adrenal cortex is not likely to affect the secretion of which one of the following?
(1) Aldosterone
(2) Both Androstenedione and Dehydroepiandrosterone
(3) Adrenaline
(4) Cortisol
∴ **Correct choice : (3)**
83. Low Ca^{++} in the body fluid may be the cause of:
(1) Tetany (2) Anaemia (3) Angina pectoris (4) Gout
∴ **Correct choice : (1)**
84. Which one of the following pairs is **incorrectly** matched?
(1) Glucagon – Beta cells (source)
(2) Somatostatin – Delta cells (source)
(3) Corpus luteum – Relaxin (secretion)
(4) Insulin – Diabetes mellitus (disease)
∴ **Correct choice : (1)**

85. Select the **correct** statement from the ones given below with respect to dihybrid cross.
- (1) Tightly linked genes on the same chromosome show higher recombinations
 - (2) Genes far apart on the same chromosome show very few recombinations
 - (3) Genes loosely linked on the same chromosome show similar recombinations as the tightly linked ones
 - (4) Tightly linked genes on the same chromosome show very few recombinations
- ∴ Correct choice : (4)**
86. Which one of the following statements in regard to the excretion by the human kidneys is **correct**?
- (1) Descending limb of Loop of Henle is impermeable to water
 - (2) Distal convoluted tubule is incapable of reabsorbing HCO_3
 - (3) Nearly 99 per cent of the glomerular filtrate is reabsorbed by the renal tubules
 - (4) Ascending limb of Loop of Henle is impermeable to electrolytes
- ∴ Correct choice : (3)**
87. The nerve centres which control the body temperature and the urge for eating are contained in:
- (1) Hypothalamus
 - (2) Pons
 - (3) Cerebellum
 - (4) Thalamus
- ∴ Correct choice : (1)**
88. The biomass available for consumption by the herbivores and the decomposers is called :
- (1) Net primary productivity
 - (2) Secondary productivity
 - (3) Standing crop
 - (4) Gross primary productivity
- ∴ Correct choice : (1)**
89. If due to some injury the chordae tendinae of the tricuspid valve of the human heart is partially non-functional, what will be the immediate effect?
- (1) The flow of blood into the aorta will be slowed down
 - (2) The 'pacemaker' will stop working
 - (3) The blood will tend to flow back into the left atrium
 - (4) The flow of blood into the pulmonary artery will be reduced
- ∴ Correct choice : (4)**

90. Ovary is half-inferior in the flowers of :

- (1) Guava (2) Plum (3) Brinjal (4) Cucumber

∴ **Correct choice : (2)**

91. Which one of the following is used as vector for cloning genes into higher organisms ?

- (1) Baculovirus
(2) **Salmonella typhimurium**
(3) **Rhizopus nigricans**
(4) Retrovirus

∴ **Correct choice : (4)**

92. The one aspect which is **not** a salient feature of genetic code, is its being:

- (1) Degenerate (2) Ambiguous (3) Universal (4) Specific

∴ **Correct choice : (2)**

93. Which one of the following is an example of **ex-situ** conservation?

- (1) Wildlife sanctuary
(2) Seed bank
(3) Sacred groves
(4) National park

∴ **Correct choice : (2)**

94. Which one of the following palindromic base sequences in DNA can be easily cut at about the middle by some particular restriction enzyme?

- (1) 5' ————— CGTTCG ————— 3'
 3' ————— ATGGTA ————— 5'
- (2) 5' ————— GATATG ————— 3'
 3' ————— CTAATA ————— 5'
- (3) 5' ————— GAATTC ————— 3'
 3' ————— CTTAAG ————— 5'
- (4) 5' ————— CACGTA ————— 3'
 3' ————— CTCAGT ————— 5'

∴ **Correct choice : (3)**

95. Which one of the following statements is **correct** with respect to AIDS?
- (1) The HIV can be transmitted through eating food together with an infected person
 - (2) Drug addicts are least susceptible to HIV infection
 - (3) AIDS patients are being fully cured cent per cent with proper care and nutrition
 - (4) The causative HIV retrovirus enters helper T-lymphocytes thus reducing their numbers

∴ **Correct choice : (4)**

96. Phototropic curvature is the result of uneven distribution of :

- (1) Gibberellin
- (2) Phytochrome
- (3) Cytokinins
- (4) Auxin

∴ **Correct choice : (4)**

97. The **Figure** given below is a diagrammatic representation of response of organisms to abiotic factors. What do a, b and c represent respectively?

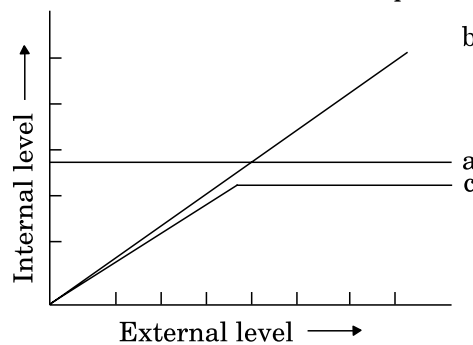

- | | | |
|-----------------------|-------------------|-------------------|
| (a) | (b) | (c) |
| (1) conformer | regulator | partial regulator |
| (2) regulator | partial regulator | conformer |
| (3) partial regulator | regulator | conformer |
| (4) regulator | conformer | partial regulator |

∴ **Correct choice : (4)**

98. Male and female gametophytes are independent and free-living in:

- (1) Mustard
- (2) Castor
- (3) **Pinus**
- (4) **Sphagnum**

∴ **Correct choice : (4)**

- 99.** The technical term used for the androecium in a flower of China rose (**Hibiscus rosasinensis**) is:
(1) Monadelphous (2) Diadelphous
(3) Polyandrous (4) Polyadelphous
∴ **Correct choice : (1)**
- 100.** Virus envelope is known as:
(1) Capsid (2) Virion
(3) Nucleoprotein (4) Core
∴ **Correct choice : (1)**
- 101.** The permissible use of the technique amniocentesis is for:
(1) detecting sex of the unborn foetus
(2) artificial insemination
(3) transfer of embryo into the uterus of the surrogate mother
(4) detecting any genetic abnormality
∴ **Correct choice : (4)**
- 102.** During mitosis ER and nucleolus begin to disappear at:
(1) Late prophase (2) Early metaphase
(3) Late metaphase (4) Early prophase
∴ **Correct choice : (1)**
- 103.** One of the free-living, anaerobic nitrogen-fixer is:
(1) **Beijernickia** (2) **Rhodospirillum**
(3) **Rhizobium** (4) **Azotobacter**
∴ **Correct choice : (2)**
- 104.** DNA or RNA segment tagged with a radioactive molecule is called:
(1) Vector (2) Probe (3) Clone (4) Plasmid
∴ **Correct choice : (2)**
- 105.** Darwin's finches are a good example of:
(1) Industrial melanism (2) Connecting link
(3) Adaptive radiation (4) Convergent evolution
∴ **Correct choice : (3)**
- 106.** The signals for parturition originate from:
(1) placenta only
(2) placenta as well as fully developed foetus
(3) oxytocin released from maternal pituitary
(4) fully developed foetus only
∴ **Correct choice : (2)**

107. What is **true** about RBCs in humans?

- (1) They carry about 20 – 25 per cent of CO₂
- (2) They transport 99.5 per cent of O₂
- (3) They transport about 80 per cent oxygen only and the rest 20 per cent of it is transported in dissolved state in blood plasma
- (4) They do not carry CO₂ at all

∴ **Correct choice : (1)**

108. Which stages of cell division do the following **figures** A and B represent respectively?

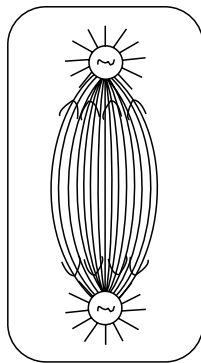

A

Fig. A

- (1) Metaphase
- (2) Telophase
- (3) Late Anaphase
- (4) Prophase

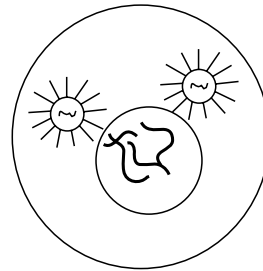

B

Fig. B

- Telophase
- Metaphase
- Prophase
- Anaphase

∴ **Correct choice : (3)**

109. The main arena of various types of activities of a cell is:

- (1) Plasma membrane
- (2) Mitochondrion
- (3) Cytoplasm
- (4) Nucleus

∴ **Correct choice : (3)**

110. The common nitrogen-fixer in paddy fields is:

- (1) **Rhizobium**
- (2) **Azospirillum**
- (3) **Oscillatoria**
- (4) **Frankia**

∴ **Correct choice : (2)**

111. The principal nitrogenous excretory compound in humans is synthesised:

- (1) in kidneys but eliminated mostly through liver
- (2) in kidneys as well as eliminated by kidneys
- (3) in liver and also eliminated by the same through bile
- (4) in the liver, but eliminated mostly through kidneys

∴ **Correct choice : (4)**

112. Carrier ions like Na^+ facilitate the absorption of substances like:

- (1) amino acids and glucose
- (2) glucose and fatty acids
- (3) fatty acids and glycerol
- (4) fructose and some amino acids

Sol.: (1) is the answer as amino acids and glucose absorption occurs through Co transport

113. Which one of the following symbols and its representation, used in human pedigree analysis is **correct**?

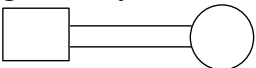
(1)  = mating between relatives

(2)  = unaffected male

(3)  = unaffected female

(4)  = male affected

∴ **Correct choice : (1)**

114. Which two of the following changes (a – d) usually tend to occur in the plain dwellers when they move to high altitudes (3,500 m or more)?

- (a) Increase in red blood cell size
- (b) Increase in red blood cell production
- (c) Increased breathing rate
- (d) Increase in thrombocyte count

Changes occurring are:

- (1) (b) and (c)
- (2) (c) and (d)
- (3) (a) and (d)
- (4) (a) and (b)

∴ **Correct choice : (1)**

115. Toxic agents present in food which interfere with thyroxine synthesis lead to the development of:

- (1) toxic goitre
- (2) cretinism
- (3) simple goitre
- (4) thyrotoxicosis

∴ **Correct choice : (3)**

- 116.** If for some reason our goblet cells are non-functional, this will adversely affect:
- (1) production of somatostatin
 - (2) secretion of sebum from the sebaceous glands
 - (3) maturation of sperms
 - (4) smooth movement of food down the intestine
- ∴ Correct choice : (4)**
- 117.** The plasma membrane consists mainly of:
- (1) phospholipids embedded in a protein bilayer
 - (2) proteins embedded in a phospholipid bilayer
 - (3) proteins embedded in a polymer of glucose molecules
 - (4) proteins embedded in a carbohydrate bilayer
- ∴ Correct choice : (2)**
- 118.** Which one of the following statements about all the four of **Spongilla**, Leech, Dolphin and Penguin is **correct**?
- (1) Penguin is homiothermic while the remaining three are poikilothermic
 - (2) Leech is a fresh water form while all others are marine
 - (3) **Spongilla** has special collared cells called choanocytes, not found in the remaining three
 - (4) All are bilaterally symmetrical
- ∴ Correct choice : (3)**
- 119.** The first movements of the foetus and appearance of hair on its head are usually observed during which month of pregnancy?
- (1) Fourth month (2) Fifth month (3) Sixth month (4) Third month
- ∴ Correct choice : (2)**
- 120.** The scutellum observed in a grain of wheat or maize is comparable to which part of the seed in other monocotyledons?
- (1) Cotyledon (2) Endosperm (3) Aleurone layer (4) Plumule
- ∴ Correct choice : (1)**
- 121.** Which one of the following kinds of animals are **triploblastic**?
- (1) Flat worms (2) Sponges (3) Ctenophores (4) Corals
- ∴ Correct choice : (1)**
- 122.** Which one of the following statements about certain given animals is **correct**?
- (1) Round worms (Aschelminthes) are pseudocoelomates
 - (2) Molluscs are acoelomates
 - (3) Insects are pseudocoelomates
 - (4) Flat worms (Platyhelminthes) are coelomates
- ∴ Correct choice : (1)**

- 123.** Cu ions released from copper – releasing Intra Uterine Devices (IUDs):
- (1) make uterus unsuitable for implantation
 - (2) increase phagocytosis of sperms
 - (3) suppress sperm motility
 - (4) prevent ovulation
- ∴ Correct choice : (3)**
- 124.** The energy – releasing metabolic process in which substrate is oxidised without an external electron acceptor is called:
- (1) Glycolysis
 - (2) Fermentation
 - (3) Aerobic respiration
 - (4) Photorespiration
- ∴ Correct choice : (1)**
- 125.** Restriction endonucleases are enzymes which:
- (1) make cuts at specific positions within the DNA molecule
 - (2) recognize a specific nucleotide sequence for binding of DNA ligase
 - (3) restrict the action of the enzyme DNA polymerase
 - (4) remove nucleotides from the ends of the DNA molecule
- ∴ Correct choice : (1)**
- 126.** Which one of the following is **not** a lateral meristem?
- (1) Intrafascicular cambium
 - (2) Interfascicular cambium
 - (3) Phellogen
 - (4) Intercalary meristem
- ∴ Correct choice : (4)**
- 127.** A renewable exhaustible natural resource is:
- (1) Coal
 - (2) Petroleum
 - (3) Minerals
 - (4) Forest
- ∴ Correct choice : (4)**
- 128.** Photoperiodism was first characterised in:
- (1) Tobacco
 - (2) Potato
 - (3) Tomato
 - (4) Cotton
- ∴ Correct choice : (1)**
- 129.** C₄ plants are more efficient in photosynthesis than C₃ plants due to:
- (1) Higher leaf area
 - (2) Presence of larger number of chloroplasts in the leaf cells
 - (3) Presence of thin cuticle
 - (4) Lower rate of photorespiration
- ∴ Correct choice : (4)**

- 130.** Algae have cell wall made up of:
(1) Cellulose, galactans and mannans
(2) Hemicellulose, pectins and proteins
(3) Pectins, cellulose and proteins
(4) Cellulose, hemicellulose and pectins
∴ Correct choice : (1)
- 131.** Some hyperthermophilic organisms that grow in highly acidic (pH2) habitats belong to the two groups:
(1) Eubacteria and archaea (2) Cyanobacteria and diatoms
(3) Protists and mosses (4) Liverworts and yeasts
∴ Correct choice : (1)
- 132.** Genetic engineering has been successfully used for producing:
(1) transgenic mice for testing safety of polio vaccine before use in humans
(2) transgenic models for studying new treatments for certain cardiac diseases
(3) transgenic Cow – Rosie which produces high fat milk for making ghee
(4) animals like bulls for farm work as they have super power
∴ Correct choice : (1)
- 133.** Some of the characteristics of Bt cotton are:
(1) Long fibre and resistance to aphids
(2) Medium yield, long fibre and resistance to beetle pests
(3) High yield and production of toxic protein crystals which kill dipteran pests
(4) High yield and resistance to bollworms
∴ Correct choice : (4)
- 134.** Heartwood differs from sapwood in:
(1) Presence of rays and fibres
(2) Absence of vessels and parenchyma
(3) Having dead and non-conducting elements
(4) Being susceptible to pests and pathogens
∴ Correct choice : (3)
- 135.** Satellite DNA is useful tool in:
(1) Organ transplantation (2) Sex determination
(3) Forensic science (4) Genetic engineering
∴ Correct choice : (3)
- 136.** The second maturation division of the mammalian ovum occurs:
(1) Shortly after ovulation before the ovum makes entry into the Fallopian tube
(2) Until after the ovum has been penetrated by a sperm
(3) Until the nucleus of the sperm has fused with that of the ovum
(4) in the Graafian follicle following the first maturation division
∴ Correct choice : (2)

137. Which one of the following does not follow the central dogma of molecular biology?
(1) Pea (2) **Mucor** (3) **Chlamydomonas** (4) HIV
∴ **Correct choice : (4)**
138. Which one of the following statements about human sperm is correct?
(1) Acrosome has a conical pointed structure used for piercing and penetrating the egg, resulting in fertilisation
(2) The sperm lysins in the acrosome dissolve the egg envelope facilitating fertilisation
(3) Acrosome serves as a sensory structure leading the sperm towards the ovum
(4) Acrosome serves no particular function
∴ **Correct choice : (2)**
139. Consider the following four statements (a – d) regarding kidney transplant and select the two correct ones out of these.
(a) Even if a kidney transplant is proper the recipient may need to take immuno-suppressants for a long time
(b) The cell-mediated immune response is responsible for the graft rejection
(c) The B-lymphocytes are responsible for rejection of the graft
(d) The acceptance or rejection of a kidney transplant depends on specific interferons
The two correct statements are:
(1) (b) and (c) (2) (c) and (d) (3) (a) and (c) (4) (a) and (b)
∴ **Correct choice : (4)**
140. Wind pollinated flowers are:
(1) small, brightly coloured, producing large number of pollen grains
(2) small, producing large number of dry pollen grains
(3) large producing abundant nectar and pollen
(4) small, producing nectar and dry pollen
∴ **Correct choice : (2)**
141. dB is a standard abbreviation used for the quantitative expression of:
(1) the density of bacteria in a medium
(2) a particular pollutant
(3) the dominant **Bacillus** in a culture
(4) a certain pesticide
∴ **Correct choice : (2)**
142. Which one of the following is one of the characteristics of a biological community?
(1) Stratification (2) **Natality** (3) **Mortality** (4) **Sex-ratio**
∴ **Correct choice : (1)**

- 143.** Which one of the following statements about morula in humans is **correct**?
- (1) It has almost equal quantity of cytoplasm as an uncleaved zygote but much more DNA
(2) It has far **less** cytoplasm as well as **less** DNA than in an uncleaved zygote
(3) It has more or less equal quantity of cytoplasm and DNA as in uncleaved zygote
(4) It has more cytoplasm and more DNA than an uncleaved zygote
∴ **Correct choice : (1)**
- 144.** Coiling of garden pea tendrils around any support is an example of:
- (1) Thigmotaxis (2) Thigmonasty (3) Thigmotropism (4) Thermotaxis
∴ **Correct choice : (3)**
- 145.** The two gases making highest relative contribution to the greenhouse gases are:
- (1) CO₂ and CH₄ (2) CH₄ and N₂O (3) CFC₅ and N₂O (4) CO₂ and N₂O
∴ **Correct choice : (1)**
- 146.** Which one of the following is **not** used in organic farming?
- (1) **Glomus** (2) Earthworm (3) **Oscillatoria** (4) Snail
∴ **Correct choice : (4)**
- 147.** Stirred-tank bioreactors have been designed for:
- (1) Addition of preservatives to the product
(2) Purification of the product
(3) Ensuring anaerobic conditions in the culture vessel
(4) Availability of oxygen throughout the process
∴ **Correct choice : (4)**
- 148.** The part of Fallopian tube closest to the ovary is:
- (1) Isthmus (2) Infundibulum (3) Cervix (4) Ampulla
∴ **Correct choice : (2)**
- 149.** An improved variety of transgenic basmati rice:
- (1) does not require chemical fertilizers and growth hormones
(2) gives high yield and is rich in vitamin A
(3) is completely resistant to all insect pests and diseases of paddy
(4) gives high yield but has no characteristic aroma
∴ **Correct choice : (3)**
- 150.** Infectious proteins are present in:
- (1) Gemini viruses (2) Prions
(3) Viroids (4) Satellite viruses
∴ **Correct choice : (2)**

PHYSICS

151. A block of mass m is in contact with the cart C as shown in the **Figure**.

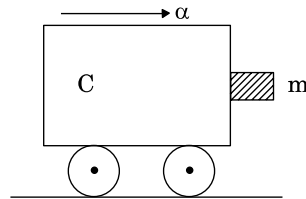

The coefficient of static friction between the block and the cart is μ . The acceleration α of the cart that will prevent the block from falling satisfies:

- (1) $\alpha > \frac{mg}{\mu}$ (2) $\alpha > \frac{g}{\mu m}$ (3) $\alpha \geq \frac{g}{\mu}$ (4) $\alpha < \frac{g}{\mu}$

Sol: $mg = \mu m \alpha$

$$\alpha \geq \frac{g}{\mu}$$

∴ Correct choice : (3)

152. The mass of a ${}^7_3\text{Li}$ nucleus is 0.042 u less than the sum of the masses of all its nucleons. The binding energy per nucleon of ${}^7_3\text{Li}$ nucleus is nearly:

- (1) 46 MeV (2) 5.6 MeV (3) 3.9 MeV (4) 23 MeV

Sol: $\Delta m = 0.042 \times 931 \approx 42 \text{ MeV}$

$$\therefore \text{B.E./ nucleon} = \frac{42}{7} = 6 \text{ MeV} \approx 5.6 \text{ MeV}$$

∴ Correct choice : (2)

153. A circular disk of moment of inertia I_t is rotating in a horizontal plane, about its symmetry axis, with a constant angular speed ω_i . Another disk of moment of inertia I_b is dropped coaxially onto the rotating disk. Initially the second disk has zero angular speed. Eventually both the disks rotate with a constant angular speed ω_f . The energy lost by the initially rotating disk to friction is:

- (1) $\frac{1}{2} \frac{I_b^2}{(I_t + I_b)} \omega_i^2$ (2) $\frac{1}{2} \frac{I_t^2}{(I_t + I_b)} \omega_i^2$
 (3) $\frac{I_b - I_t}{(I_t + I_b)} \omega_i^2$ (4) $\frac{1}{2} \frac{I_b I_t}{(I_t + I_b)} \omega_i^2$

Sol: $I_t - \omega_i$ $\omega_f = \frac{I_t}{I_t + I_b} \omega_i$

$$(I_t + I_b) - \omega_f$$

$$\begin{aligned} \Delta K &= \frac{1}{2} I_t \omega_i^2 - \frac{1}{2} (I_t + I_b) \frac{I_t^2}{(I_t + I_b)^2} \omega_i^2 \\ &= \frac{1}{2} \omega_i^2 \frac{I_t}{I_t + I_b} (I_t + I_b - I_t) = \frac{1}{2} \omega_i^2 \frac{I_t I_b}{I_t + I_b} \end{aligned}$$

∴ Correct choice : (4)

154. Which one of the following statement is FALSE?

- (1) Pure Si doped with trivalent impurities gives a p-type semiconductor
- (2) Majority carriers in a n-type semiconductor are holes
- (3) Minority carriers in a p-type semiconductor are electrons
- (4) The resistance of intrinsic semiconductor decreases with increase of temperature

∴ Correct choice : (2)

155. The displacement of a particle along the x-axis is given by $x = a \sin^2 \omega t$. The motion of the particle corresponds to:

- (1) simple harmonic motion of frequency ω/π
- (2) simple harmonic motion of frequency $3\omega/2\pi$
- (3) non simple harmonic motion
- (4) simple harmonic motion of frequency $\omega/2\pi$

Sol: $x = a \sin^2 \omega t = \frac{a}{2} (1 - \cos 2\omega t)$

$$\frac{dx}{dt} = \frac{a}{2} 2\omega \sin 2\omega t, \quad \frac{d^2x}{dt^2} = \frac{4\omega^2 a}{2} \cdot \cos 2\omega t$$

$$\text{SHM of frequency} = \frac{\omega}{\pi}$$

∴ Correct choice : (1)

156. The radii of circular orbits of two satellites A and B of the earth, are $4R$ and R , respectively. If the speed of satellite A is $3V$, then the speed of satellite B will be:

- (1) $3V/4$ (2) $6V$ (3) $12V$ (4) $3V/2$

Sol: $\frac{V^2}{r} = \frac{K}{r^2} \Rightarrow rV^2 = \text{constant}$

$$r_1 V_1^2 = r_2 V_2^2$$

$$V_2 = V_1 \sqrt{\frac{r_1}{r_2}} = V_1 \sqrt{\frac{4R}{R}} = 2V_1 = 6V$$

∴ Correct choice : (2)

157. A beam of cathode rays is subjected to crossed Electric (E) and Magnetic fields (B). The fields are adjusted such that the beam is not deflected. The specific charge of the cathode rays is given by:

- (1) $\frac{B^2}{2VE^2}$ (2) $\frac{2VB^2}{E^2}$ (3) $\frac{2VE^2}{B^2}$ (4) $\frac{E^2}{2VB^2}$

(Where V is the potential difference between cathode and anode)

Sol: $eE = eVB$ $V = \frac{E}{B}$

$$\frac{1}{2}mv^2 = eV \quad \therefore \frac{e}{m} = \frac{v^2}{2V} = \frac{E^2}{2VB^2}$$

∴ Correct choice : (4)

158. A ball is dropped from a high rise platform at $t = 0$ starting from rest. After 6 seconds another ball is thrown downwards from the same platform with a speed v . The two balls meet at $t = 18$ s. What is the value of v ?

(take $g = 10 \text{ m/s}^2$)

- (1) 75 m/s (2) 55 m/s (3) 40 m/s (4) 60 m/s

Sol: Distance moved in 18 s by I ball = $\frac{1}{2} \times 10 \times 18^2$
 $= 90 \times 18 = 1620 \text{ m}$

Distance moved in 12 s by II ball = $ut + \frac{1}{2}gt^2$

$$\therefore 1620 = 12u + 5 \times 144$$

$$u = 135 - 60 = 75 \text{ ms}^{-1}$$

∴ Correct choice : (1)

159. A ray of light travelling in a transparent medium of refractive index μ , falls on a surface separating the medium from air at an angle of incidence of 45° . For which of the following value of μ the ray can undergo total internal reflection?

- (1) $\mu = 1.33$ (2) $\mu = 1.40$ (3) $\mu = 1.50$ (4) $\mu = 1.25$

Sol: $\mu \geq \frac{1}{\sin C} \geq \sqrt{2} \geq 1.414 \Rightarrow \mu = 1.50$

\therefore Correct choice : (3)

160. The period of oscillation of a mass M suspended from a spring of negligible mass is T . If along with it another mass M is also suspended, the period of oscillation will now be:

- (1) T (2) $T/\sqrt{2}$ (3) $2T$ (4) $\sqrt{2} T$

Sol: $T = 2\pi \sqrt{\frac{m}{R}}$

$$\therefore \frac{T_1}{T_2} = \sqrt{\frac{M_1}{M_2}} \quad \therefore T_2 = T_1 \sqrt{\frac{M_2}{M_1}} = T_1 \sqrt{\frac{2M}{M}}$$

$$T_2 = T_1 = \sqrt{2} T \text{ (where } T_1 = T)$$

\therefore Correct choice : (4)

161. A cylindrical metallic rod in thermal contact with two reservoirs of heat at its two ends conducts an amount of heat Q in time t . The metallic rod is melted and the material is formed into a rod of half the radius of the original rod. What is the amount of heat conducted by the new rod, when placed in thermal contact with the two reservoirs in time t ?

- (1) $\frac{Q}{4}$ (2) $\frac{Q}{16}$ (3) $2Q$ (4) $\frac{Q}{2}$

Sol: $\frac{Q}{t} = K.A. \frac{\Delta T}{\ell}$ $A = \pi R^2$; $\pi R^2 \ell = \pi \left(\frac{R'}{2}\right)^2 \ell'$

$$A' = \frac{\pi R^2}{4}; \quad \frac{\ell'}{\ell} = \frac{R^2}{\left(\frac{R'}{2}\right)^2}$$

$$\frac{Q'}{Q} = \frac{A'}{A} \frac{\ell}{\ell'} = \frac{1}{4} \cdot \frac{1}{4} = \frac{1}{16}$$

$$\therefore Q' = \frac{Q}{16}$$

\therefore Correct choice : (2)

162. A ball moving with velocity 2 m/s collides head on with another stationary ball of double the mass. If the coefficient of restitution is 0.5, then their velocities (in m/s) after collision will be:

- (1) 0, 1 (2) 1, 1 (3) 1, 0.5 (4) 0, 2

Sol: $m - u = 2 \text{ ms}^{-1}, 2m - 0$

$$e = \frac{v_1' - v_2'}{v_2 - v_1}$$

$$2m = mv_1 + 2mv_2$$

$$0.5 = \frac{v_2 - v_1}{2} \therefore v_2 = 1 + v_1$$

$$2 = v_1 + 2 + 2v_1, v_1 = 0, v_2 = 1 \text{ ms}^{-1}$$

∴ Correct choice : (1)

163. A transverse wave is represented by $y = A \sin (\omega t - kx)$. For what value of the wavelength is the wave velocity equal to the maximum particle velocity?

- (1) $\frac{\pi A}{2}$ (2) πA (3) $2 \pi A$ (4) A

Sol: $y = A \sin (\omega t - kx)$

$$v_p = \frac{dy}{dt} = A \omega \cos (\omega t - kx)$$

$$v_{p \max} = A \omega = \frac{\omega}{k} \quad \text{i.e., } A = \frac{1}{k}, k = \frac{2\pi}{\lambda}$$

$$\therefore \lambda = 2 \pi A$$

∴ Correct choice : (3)

164. A particle has initial velocity $(3\hat{i} + 4\hat{j})$ and has acceleration $(0.4\hat{i} + 0.3\hat{j})$. Its speed after 10 s is:

- (1) 7 units (2) $7\sqrt{2}$ units (3) 8.5 units (4) 10 units

Sol: $\vec{u} = 3\hat{i} + 4\hat{j}, \vec{a} = 0.4\hat{i} + 0.3\hat{j}$

$$v_x = u_x + a_x \times 10 = 3 + 4 = 7 \text{ ms}^{-1}$$

$$v_y = 4 + 0.3 \times 10 = 4 + 3 = 7 \text{ ms}^{-1}$$

$$\therefore v = \sqrt{v_x^2 + v_y^2} = 7\sqrt{2} \text{ ms}^{-1}$$

∴ Correct choice : (2)

165. An engine pumps water through a hose pipe. Water passes through the pipe and leaves it with a velocity of 2 m/s. The mass per unit length of water in the pipe is 100 kg/m. What is the power of the engine?

- (1) 400 W (2) 200 W (3) 100 W (4) 800 W

Sol: Amount of water flowing per second

$$= \frac{m}{\text{time}} = \frac{m}{\ell} \cdot \frac{\ell}{t} = \left(\frac{m}{\ell} \right) v$$

$$\text{K.E. of water flowing per second} = \text{power} = \frac{1}{2} \left(\frac{m}{\ell} \right) v^3$$

$$= \frac{1}{2} \times 100 \times 8 = 400 \text{ W}$$

∴ Correct choice : (1)

166. A thin ring of radius R meter has charge q coulomb uniformly spread on it. The ring rotates about its axis with a constant frequency of f revolutions/s. The value of magnetic induction in Wb/m^2 at the centre of the ring is:

- (1) $\frac{\mu_0 q f}{2\pi R}$ (2) $\frac{\mu_0 q}{2\pi f R}$ (3) $\frac{\mu_0 q}{2f R}$ (4) $\frac{\mu_0 q f}{2R}$

Sol: Current $I = \frac{q}{T} = \frac{q\omega}{2\pi}$

$$B = \frac{\mu_0 I}{2R} = \frac{\mu_0}{2R} \cdot \frac{q2\pi f}{2\pi} = \frac{\mu_0 q f}{2R}$$

∴ Correct choice : (4)

167. Which one of the following bonds produces a solid that reflects light in the visible region and whose electrical conductivity decreases with temperature and has high melting point?

- (1) metallic bonding
(2) van der Waal's bonding
(3) ionic bonding
(4) covalent bonding

Sol: Metal – conductivity decreases with increase in temperature.

∴ Correct choice : (1)

168. A particle moves a distance x in time t according to equation $x = (t + 5)^{-1}$. The acceleration of particle is proportional to:

- (1) (velocity)^{3/2} (2) (distance)² (3) (distance)⁻² (4) (velocity)^{2/3}

Sol: $x = \frac{1}{t + 5}$, $\frac{dx}{dt} = \frac{-1}{(t + 5)^2} = v$

$$\frac{d^2x}{dt^2} = \frac{2}{(t + 5)^3} = 2x^3$$

Now $\frac{1}{(t + 5)} \propto v^2$

$$\therefore \frac{1}{(t + 5)^3} \propto v^{\frac{3}{2}} \propto \frac{d^2x}{dt^2}$$

∴ Correct choice : (1)

169. A conducting circular loop is placed in a uniform magnetic field, $B = 0.025$ T with its plane perpendicular to the loop. The radius of the loop is made to shrink at a constant rate of 1 mm s^{-1} . The induced e.m.f. when the radius is 2 cm, is:

- (1) $2\pi \mu\text{V}$ (2) $\pi \mu\text{V}$ (3) $\frac{\pi}{2} \mu\text{V}$ (4) $2 \mu\text{V}$

Sol: $\phi = B\pi r^2$, $|e| = \frac{d\phi}{dt} = B\pi \cdot 2r \frac{dr}{dt}$

When $r = 2 \text{ cm}$, $\frac{dr}{dt} = 1 \text{ mm s}^{-1}$

$$e = 0.025 \times \pi \times 2 \times 2 \times 10^{-2} \times 10^{-3}$$

$$= 0.100 \times \pi \times 10^{-5} = \pi \mu\text{V}$$

∴ Correct choice : (2)

170. The activity of a radioactive sample is measured as N_0 counts per minute at $t = 0$ and N_0/e counts per minute at $t = 5$ minutes. The time (in minutes) at which the activity reduces to half its value is:

- (1) $\log_e 2/5$ (2) $\frac{5}{\log_e 2}$ (3) $5 \log_{10} 2$ (4) $5 \log_e 2$

Sol: $N = N_0 e^{-\lambda t}$, $t = 5 \text{ min.}$ $\frac{N_0}{e} = N_0 \cdot e^{-5\lambda}$

$$5\lambda = 1, \lambda = \frac{1}{5}, T_{1/2} = \frac{\ln 2}{\lambda} = 5 \ln 2$$

∴ Correct choice : (4)

171. Two particles which are initially at rest, move towards each other under the action of their internal attraction. If their speeds are v and $2v$ at any instant, then the speed of centre of mass of the system will be:

- (1) $2v$ (2) Zero (3) $1.5v$ (4) v

Sol: No change in state of motion of COM due to internal forces.

\therefore speed of COM = zero

\therefore **Correct choice : (2)**

172. A particle of mass M is situated at the centre of a spherical shell of same mass and radius a . The gravitational potential at a point situated at $\frac{a}{2}$ distance from the centre, will be:

- (1) $-\frac{3GM}{a}$ (2) $-\frac{2GM}{a}$ (3) $-\frac{GM}{a}$ (4) $-\frac{4GM}{a}$

Sol: Potential at a point = $-\frac{GM}{a} - \frac{2GM}{a} = -\frac{3GM}{a}$

\therefore **Correct choice : (1)**

173. The device that can act as a complete electronic circuit is:

- (1) Junction diode (2) Integrated circuit
(3) Junction transistor (4) Zener diode

\therefore **Correct choice : (2)**

174. A potentiometer circuit is set up as shown. The potential gradient, across the potentiometer wire, is k volt/cm and the ammeter, present in the circuit, reads 1.0 A when two way key is switched off. The balance points, when the key between the terminals (i) 1 and 2 (ii) 1 and 3, is plugged in, are found to be at lengths l_1 cm and l_2 cm respectively. The magnitudes, of the resistors R and X , in ohms, are then, equal, respectively, to:

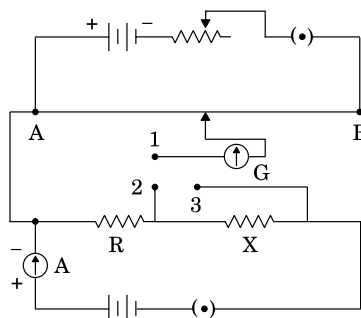

- (1) $k(l_2 - l_1)$ and kl_2 (2) kl_1 and $k(l_2 - l_1)$
(3) $k(l_2 - l_1)$ and kl_1 (4) kl_1 and kl_2

Sol: P.D. across $R = IR = kl_1 \longrightarrow R = kl_1 \quad I = 1 \text{ A}$

P.D. across $(X + R) = I(X + R) = kl_2 \longrightarrow X + R = kl_2$

$$X = k(l_2 - l_1)$$

$$\therefore R = kl_1, \quad X = k(l_2 - l_1)$$

\therefore Correct choice : (2)

175. A tuning fork of frequency 512 Hz makes 4 beats per second with the vibrating string of a piano. The beat frequency decreases to 2 beats per sec when the tension in the piano string is slightly increased. The frequency of the piano string before increasing the tension was:

- (1) 510 Hz (2) 514 Hz (3) 516 Hz (4) 508 Hz

Sol: $\Delta n_1 = 4, \quad 512 \pm 4.$

$\Delta n_2 = 4$, when tension is increased, frequency increases. As number of beats decreased, the frequency of string $< 512 \Rightarrow 508 \text{ Hz}$

\therefore Correct choice : (4)

176. Six vectors, \vec{a} through \vec{f} have the magnitudes and directions indicated in the figure. Which of the following statements is true?

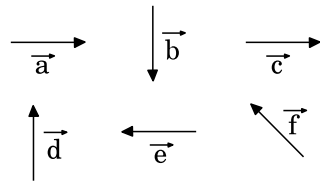

- (1) $\vec{b} + \vec{c} = \vec{f}$ (2) $\vec{d} + \vec{c} = \vec{f}$
 (3) $\vec{d} + \vec{e} = \vec{f}$ (4) $\vec{b} + \vec{e} = \vec{f}$

Sol: $\vec{d} + \vec{e} =$

$$\therefore \vec{d} + \vec{e} = \vec{f}$$

\therefore Correct choice : (3)

177. A galvanometer has a coil of resistance 100 ohm and gives a full-scale deflection for 30 mA current. If it is to work as a voltmeter of 30 volt range, the resistance required to be added will be:

- (1) 900 Ω (2) 1800 Ω (3) 500 Ω (4) 1000 Ω

Sol: $30 = I_g (r + R)$

$$\begin{aligned} \therefore R &= \frac{30}{I_g} - r = \frac{30}{30 \times 10^{-3}} - 100 \\ &= 1000 - 100 = 900 \Omega \end{aligned}$$

∴ Correct choice : (1)

178. A gramophone record is revolving with an angular velocity ω . A coin is placed at a distance r from the centre of the record. The static coefficient of friction is μ . The coin will revolve with the record if:

(1) $r = \mu g \omega^2$ (2) $r < \frac{\omega^2}{\mu g}$ (3) $r \leq \frac{\mu g}{\omega^2}$ (4) $r \geq \frac{\mu g}{\omega^2}$

Sol: $mr\omega^2 \leq \mu mg$

$$r \leq \frac{\mu g}{\omega^2}$$

∴ Correct choice : (3)

179. Which of the following statement is **false** for the properties of electromagnetic waves?

- (1) Both electric and magnetic field vectors attain the maxima and minima at the same place and same time
 (2) The energy in electromagnetic wave is divided equally between electric and magnetic vectors
 (3) Both electric and magnetic field vectors are parallel to each other and perpendicular to the direction of propagation of wave
 (4) These waves do not require any material medium for propagation

∴ Correct choice : (3)

180. The energy of a hydrogen atom in the ground state is -13.6 eV. The energy of a He^+ ion in the first excited state will be:

- (1) -13.6 eV (2) -27.2 eV (3) -54.4 eV (4) -6.8 eV

Sol: $E_{\text{He}^+} = -Z^2 \times \frac{13.6}{n^2}$

First excited state: $n = 2$, $Z = 2$ for Helium.

$$\therefore E_{\text{He}^+} = -\frac{4}{2^2} \times 13.6 = -13.6 \text{ eV}$$

∴ Correct choice : (1)

181. The dimension of $\frac{1}{2} \epsilon_0 E^2$, where ϵ_0 is permittivity of free space and E is electric field, is:

- (1) $ML^2 T^{-2}$ (2) $ML^{-1} T^{-2}$ (3) $ML^2 T^{-1}$ (4) MLT^{-1}

Sol: $\frac{1}{2} \epsilon_0 E^2$

$$\Rightarrow \text{energy density} = \frac{ML^2 T^{-2}}{L^3} = ML^{-1} T^{-2}$$

∴ Correct choice : (2)

182. In producing chlorine by electrolysis 100 kW power at 125 V is being consumed. How much chlorine per minute is liberated? (E.C.E. of chlorine is 0.367×10^{-6} kg/C)

- (1) 1.76×10^{-3} kg (2) 9.67×10^{-3} kg
(3) 17.61×10^{-3} kg (4) 3.67×10^{-3} kg

Sol: $I = \frac{100 \times 10^3}{125}$ A

$$\text{E.C.E} = 0.367 \times 10^{-6} \text{ kg C}^{-1}$$

$$\text{Charge per minute} = \frac{10^5 \times 60}{125} \text{ C}$$

$$\begin{aligned} \text{Mass liberated} &= \frac{6 \times 10^6}{125} \times 0.367 \times 10^{-6} \\ &= \frac{6 \times 1000 \times 0.367 \times 10^{-3}}{125} = 17.616 \times 10^{-3} \text{ kg} \end{aligned}$$

∴ Correct choice : (3)

183. A man of 50 kg mass is standing in a gravity free space at a height of 10 m above the floor. He throws a stone of 0.5 kg mass downwards with a speed 2 m/s. When the stone reaches the floor, the distance of the man above the floor will be:

- (1) 9.9 m (2) 10.1 m (3) 10 m (4) 20 m

Sol: By momentum conservation,

$$50 u + 0.5 \times 2 = 0$$

$$u = -\frac{1}{50} \text{ ms}^{-1}$$

$$\left[\frac{1}{50} \text{ ms}^{-1} \text{ upward} \right]$$

Time taken $t = \frac{10}{2} = 5 \text{ s}$

Distance moved by the man $= 5 \times \frac{1}{50} = 0.1 \text{ m}$

\therefore when the stone reaches the floor, the distance of the man above floor $= 10.1 \text{ m}$

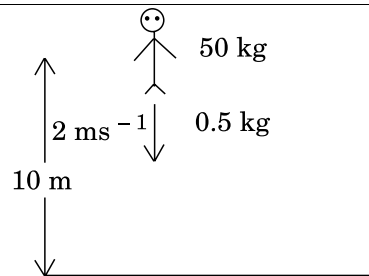

\therefore **Correct choice : (2)**

184. An alpha nucleus of energy $\frac{1}{2} mv^2$ bombards a heavy nuclear target of charge Ze .

Then the distance of closest approach for the alpha nucleus will be proportional to:

- (1) $\frac{1}{Ze}$ (2) v^2 (3) $\frac{1}{m}$ (4) $\frac{1}{v^4}$

Sol: $\frac{1}{2} mv^2 = \frac{1}{4\pi\epsilon_0} \frac{q_\alpha Ze}{r_0}$ $r_0 \propto Ze \cdot \propto q_\alpha$

$$r_0 = \frac{2}{4\pi\epsilon_0} \frac{q_\alpha Ze}{mv^2} \quad \propto \frac{1}{m} \Rightarrow (3)$$

$$\propto \frac{1}{v^2}$$

\therefore **Correct choice : (3)**

185. A lens having focal length f and aperture of diameter d forms an image of intensity I . Aperture of diameter $\frac{d}{2}$ in central region of lens is covered by a black paper. Focal length of lens and intensity of image now will be respectively:

- (1) f and $\frac{I}{4}$ (2) $\frac{3f}{4}$ and $\frac{I}{2}$ (3) f and $\frac{3I}{4}$ (4) $\frac{f}{2}$ and $\frac{I}{2}$

Sol: By covering aperture, focal length does not change. But intensity is reduced by $\frac{1}{4}$ times.

$$I' = \frac{3I}{4}$$

$$\therefore f, \frac{3I}{4}$$

\therefore **Correct choice : (3)**

186. If ΔU and ΔW represent the increase in internal energy and work done by the system respectively in a thermodynamical process, which of the following is true?

- (1) $\Delta U = -\Delta W$, in a adiabatic process
 (2) $\Delta U = \Delta W$, in a isothermal process
 (3) $\Delta U = \Delta W$, in a adiabatic process
 (4) $\Delta U = -\Delta W$, in a isothermal process

Sol: $\Delta Q = \Delta U + \Delta W$

In adiabatic, $\Delta Q = 0$

$$\therefore \Delta U = -\Delta W$$

In isothermal, $\Delta U = 0$

\therefore **Correct choice : (1)**

187. The total radiant energy per unit area, normal to the direction of incidence, received at a distance R from the centre of a star of radius r , whose outer surface radiates as a black body at a temperature T K is given by:

- (1) $\frac{\sigma r^2 T^4}{R^2}$ (2) $\frac{\sigma r^2 T^4}{4\pi r^2}$ (3) $\frac{\sigma r^4 T^4}{r^4}$ (4) $\frac{4\pi\sigma r^2 T^4}{R^2}$

(Where σ is Stefan's constant)

$$\begin{aligned} \text{Sol: } E &= \frac{S}{S_0} \sigma T^4 = \frac{4\pi r^2}{4\pi R^2} \sigma T^4 \\ &= \sigma \frac{r^2}{R^2} T^4 \end{aligned}$$

\therefore **Correct choice : (1)**

188. In the given circuit the reading of voltmeter V_1 and V_2 are 300 volts each. The reading of the voltmeter V_3 and ammeter A are respectively:

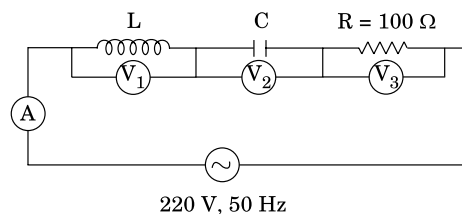

- (1) 150 V, 2.2 A (2) 220 V, 2.2 A (3) 220 V, 2.0 A (4) 100 V, 2.0 A

Sol: $V_L = V_C = 300 \text{ V} \Rightarrow \text{resonance}$

$$\therefore V_R = 220 \text{ V}, I = \frac{220}{100} = 2.2 \text{ A}$$

$$\therefore (220 \text{ V}, 2.2 \text{ A})$$

\therefore Correct choice : (2)

189. A 220 volts input is supplied to a transformer. The output circuit draws a current of 2.0 ampere at 440 volts. If the efficiency of the transformer is 80%, the current drawn by the primary windings of the transformer is:

- (1) 3.6 ampere (2) 2.8 ampere (3) 2.5 ampere (4) 5.0 ampere

Sol: $\frac{V_2}{V_1} = 0.8 \frac{I_1}{I_2} \Rightarrow \frac{V_2 I_2}{V_1 I_1} = 0.8$

$$V_1 = 220 \text{ V}, I_2 = 2.0 \text{ A}, V_2 = 440 \text{ V}$$

$$\begin{aligned} I_1 &= \frac{V_2 I_2}{V_1} \times \frac{10}{8} \\ &= \frac{440 \times 2 \times 10}{220 \times 8} \\ &= 5 \text{ A} \end{aligned}$$

\therefore Correct choice : (4)

190. A source S_1 is producing, 10^{15} photons per second of wavelength 5000 \AA . Another source S_2 is producing 1.02×10^{15} photons per second of wavelength 5100 \AA

Then, (power of S_2)/(power of S_1) is equal to:

- (1) 1.00 (2) 1.02 (3) 1.04 (4) 0.98

Sol: Energy emitted/sec by S_1 , $P_1 = n_1 \frac{hc}{\lambda_1}$

Energy emitted/sec by S_2 , $P_2 = n_2 \frac{hc}{\lambda_2}$

$$\begin{aligned} \therefore \frac{P_2}{P_1} &= \frac{n_2}{n_1} \cdot \frac{\lambda_1}{\lambda_2} \\ &= \frac{1.02 \times 10^{15}}{10^{15}} \cdot \frac{5000}{5100} = 1.0 \end{aligned}$$

\therefore Correct choice : (1)

191. A common emitter amplifier has a voltage gain of 50, an input impedance of 100Ω and an output impedance of 200Ω . The power gain of the amplifier is:

- (1) 500 (2) 1000 (3) 1250 (4) 50

Sol: Power gain = $V_G \cdot I_G = \frac{V_o}{V_i} \cdot \frac{I_o}{I_i}$

$$= \frac{V_o^2}{V_i^2} \cdot \frac{R_i}{R_o} = 50 \times 50 \times \frac{100}{200}$$

$$= \frac{2500}{2} = 1250$$

∴ Correct choice : (3)

192. A vibration magnetometer placed in magnetic meridian has a small bar magnet. The magnet executes oscillations with a time period of 2 sec in earth's horizontal magnetic field of 24 microtesla. When a horizontal field of 18 microtesla is produced opposite to the earth's field by placing a current carrying wire, the new time period of magnet will be:

- (1) 1 s (2) 2 s (3) 3 s (4) 4 s

Sol: Time period, $T \propto \frac{1}{\sqrt{B}}$

$$\frac{T_1}{T_2} = \sqrt{\frac{B_2}{B_1}}, T_2 = T_1 \sqrt{\frac{B_1}{B_2}}$$

$$= 2 \sqrt{\frac{24 \times 10^{-6}}{6 \times 10^{-6}}} = 4 \text{ s}$$

∴ Correct choice : (4)

193. Two positive ions, each carrying a charge q , are separated by a distance d . If F is the force of repulsion between the ions, the number of electrons missing from each ion will be (e being the charge of an electron):

- (1) $\frac{4\pi\epsilon_0 Fd^2}{e^2}$ (2) $\sqrt{\frac{4\pi\epsilon_0 Fe^2}{d^2}}$ (3) $\sqrt{\frac{4\pi\epsilon_0 Fd^2}{e^2}}$ (4) $\frac{4\pi\epsilon_0 Fd^2}{q^2}$

Sol: $F = \frac{1}{4\pi\epsilon_0} \cdot \frac{q^2}{d^2} \Rightarrow q = \sqrt{4\pi\epsilon_0 d^2 F} = ne$

$$\therefore n = \sqrt{\frac{4\pi\epsilon_0 Fd^2}{e^2}}$$

∴ Correct choice : (3)

194. The potential difference that must be applied to stop the fastest photoelectrons emitted by a nickel surface, having work function 5.01 eV, when ultraviolet light of 200 nm falls on it, must be:

- (1) 2.4 V (2) – 1.2 V (3) – 2.4 V (4) 1.2 V

Sol: $K_{\max} = \frac{hc}{\lambda} - 5.01 = \frac{12375}{\lambda(\text{in } \text{Å})} - 5.01$

$$= \frac{12375}{2000} - 5.01 = 6.1875 - 5.01 = 1.1775 \approx 1.2 \text{ V}$$

∴ **Correct choice : (4)**

195. A square surface of side L meter in the plane of the paper is placed in a uniform electric field E (volt/m) acting along the same plane at an angle θ with the horizontal side of the square as shown in **Figure**. The electric flux linked to the surface, in units of volt. m, is:

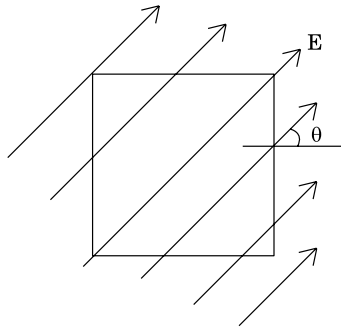

- (1) EL^2 (2) $EL^2 \cos \theta$ (3) $EL^2 \sin \theta$ (4) Zero

Sol: $\phi = EA \cos \theta$, θ – angle between E and normal to the surface,

here $\theta = \frac{\pi}{2} \Rightarrow \phi = 0$

∴ **Correct choice : (4)**

196. A series combination of n_1 capacitors, each of value C_1 , is charged by a source of potential difference 4 V. When another parallel combination of n_2 capacitors, each of value C_2 , is charged by a source of potential difference V, it has the same (total) energy stored in it, as the first combination has. The value of C_2 , in terms of C_1 , is then:

- (1) $\frac{2 C_1}{n_1 n_2}$ (2) $16 \frac{n_2}{n_1} C_1$ (3) $2 \frac{n_2}{n_1} C_1$ (4) $\frac{16 C_1}{n_1 n_2}$

Sol: 1. Series $C_{\text{eff}} = \frac{C_1}{n_1}$, $E_S = \frac{1}{2} C_{\text{eff}} V_S^2 = \frac{1}{2} \frac{C_1}{n_1} 16 V^2$

$$= 8 V^2 \frac{C_1}{n_1}$$

2. Parallel $C_{\text{eff}} = n_2 C_2$, $E_P = \frac{1}{2} n_2 C_2 V^2$

$$\therefore \frac{8 V^2 C_1}{n_1} = \frac{1}{2} n_2 C_2 V^2$$

$$C_2 = \frac{16 C_1}{n_1 n_2}$$

∴ Correct choice : (4)

197. Electromagnets are made of soft iron because soft iron has:

- (1) low retentivity and high coercive force
- (2) high retentivity and high coercive force
- (3) low retentivity and low coercive force
- (4) high retentivity and low coercive force

∴ Correct choice : (4)

198. A square current carrying loop is suspended in a uniform magnetic field acting in the plane of the loop. If the force on one arm of the loop is \vec{F} , the net force on the remaining three arms of the loop is:

- (1) $3 \vec{F}$
- (2) $-\vec{F}$
- (3) $-3 \vec{F}$
- (4) \vec{F}

Sol:

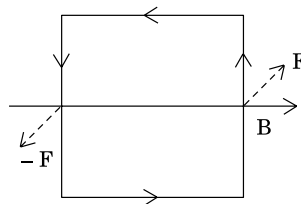

Force on remaining arms = $-\vec{F}$

∴ Correct choice : (2)

199. Consider the following two statements:

- (A) Kirchhoff's junction law follows from the conservation of charge.
- (B) Kirchhoff's loop law follows from the conservation of energy.

Which of the following is correct?

- (1) Both (A) and (B) are wrong
- (2) (A) is correct and (B) is wrong
- (3) (A) is wrong and (B) is correct
- (4) Both (A) and (B) are correct

Sol: Junction – conservation of charge
 Loop – conservation of energy

∴ Correct choice : (4)

200. To get an output $Y = 1$ from the circuit shown below, the input must be:

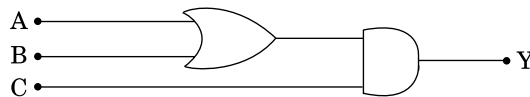

- | | A | B | C |
|-----|---|---|---|
| (1) | 0 | 1 | 0 |
| (2) | 0 | 0 | 1 |
| (3) | 1 | 0 | 1 |
| (4) | 1 | 0 | 0 |

Sol:

A	B	C	Y
0	1	0	0
0	0	1	0
1	0	1	1
1	0	0	0

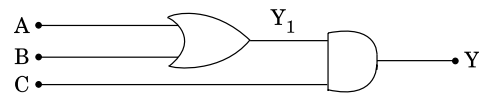

∴ Input: (1 0 1)

∴ Correct choice : (3)